

MINIMUM UNIVERSAL DESIGN REQUIREMENTS FOR NEW CONSTRUCTION USING AFFORDABLE HOUSING TRUST FUNDS FROM THE CITY OF ST. LOUIS

September 2004

Revised September 2009

OVERVIEW

All developers must hire a registered project architect to produce sealed, detailed construction drawings prior to commencing construction and to oversee construction of the project. All new construction projects require written architectural certification at the time of application, at execution of the loan agreement, and at close-out by the project architect and the developer that the project as designed and as-built complies with AHC's UD Requirements. The developer must not start construction prior to submitting sealed, detailed construction drawings, UD Certifications and waiver requests, or prior to AHC's approval and return of executed project legal documents. If AHC determines that construction has begun prior to review of the required submissions and/or errors in construction performed, AHC may revoke its funding, regardless if the variance was intentional or unintentional on the developer's part.

The first certification will state that the project will be drawn and built in compliance with AHC's Universal Design Requirements. If the developer knows at the time of application that a waiver will be needed from specific UD Requirements, the developer should request a waiver at that time. When requesting a waiver, the developer must also provide alternative designs that address resident accessibility and ease of use. Waivers and their alternative design features will be tracked throughout construction and at close-out.

Following the awarding of funds, and prior to construction, the developer and architect must sign a second certification that will include a verification checklist. Should a waiver be needed, it must be applied for a minimum of 90 days in advance of construction. This will provide the Commission the necessary time to review the request. A third and final certification will state that the project as drawn and as-built is in compliance with AHC's Universal Design Requirements.

CHAPTER 1 – APPLICATION AND ADMINISTRATION

SECTION 101 PURPOSE

Universal Design (UD) and Affordable Housing are natural and inevitable partners. The fundamental objectives are to address housing for a population facing financial and physical challenges.

The mission of the Affordable Housing Commission of the City of St. Louis is:

"To promote City living and neighborhood stabilization through the preservation of affordable, accessible housing and support services that enhance the quality of life for those in need."

The Commission provides grants and loans to non-profit agencies and developers that provide housing related services or construction/rehab housing for city residents earning 80% or below the area median income.

Houses developed through this program are intended for a wide range of occupants including all ages and physical abilities. To best meet the needs of our St. Louis residents, the Affordable Housing Commission requires all new construction built using the program to comply with basic minimum Universal Design concepts and techniques. Projects incorporating additional universal design elements may be given extra support and consideration.

"A universal house begins with three essential components: a step-less entry, wider doors and halls, and a usable bathroom. Without them, no dwelling can be considered universal. Conversely, a home with only those three features isn't universal either. In addition to the Basic 3, a universal home includes a variety of other features that provide convenience, safety, and ease of use. The combination produces a universal home." (Center for Universal Design, 2000).

Please note, AHC Requirements also include at least one accessible bedroom on an accessible level connected to the accessible route.

SECTION 102 CODES AND STANDARDS

The UD criteria are not a substitute for compliance with the current City of St. Louis Building Code and Fair Housing Act requirements. These criteria must be addressed in addition to compliance with code and accessibility requirements. In some cases, these tasks overlap; in others, the UD element is clearly an additional requirement. In many cases the UD components echo and repeat requirements that are already fundamental to most large construction projects. Compliance with these guidelines does *not* provide safe haven for compliance with any other applicable standard. Plan review for compliance with UD criteria is separate from City of St. Louis Building Division review and is not included in the permit process.

In some cases, these criteria depend on the requirements of other publications to set the standard for the construction and detailing of a required element. For example, since ramps must comply with current ANSI A117.1, Accessible and Usable Buildings and Facilities standards as currently adopted by the City of St. Louis, those requirements are not restated in these guidelines, but are simply referenced.

Asterisks indicate items which are discussed in greater detail in Appendix A: Design Notes and Explanatory Comments.

SECTION 103 DEFINED TERMS *

accessible route: A continuous, unobstructed path that complies with Sections 301 and 302. With exception of ramped surfaces, all portions of an accessible UD route slope less than 5% (1:20) parallel to travel, have a cross-slope of less than 2% (1:50), and are at least 42" wide. Accessible routes are free of protruding objects.

forward approach: Provide forward approach to an element by providing a 30"x 48" clear and level space immediately in front of and centered on the item. See illustration 103a.

level: a surface or landing sloping less than 2% in all directions

parallel approach: Provide parallel approach to an element by making sure that a 30"x 48" clear and level space is provided immediately in front of and centered on the item. See illustration 103b.

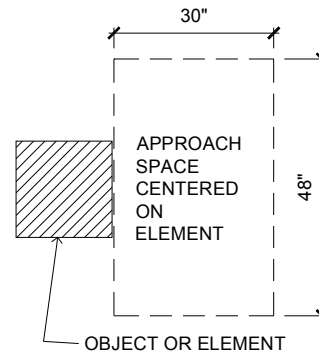
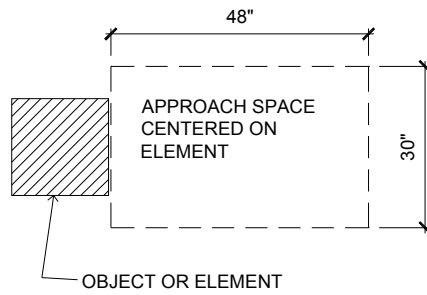

103a Forward Approach

103b Parallel Approach

protruding object: An object protruding more than four inches from a wall, at a height higher than 27”, and less than 80” above the floor. Less than 27” above the floor is considered cane detectable.

ramp*: A surface with a running slope more than 1:20 and equal to or less than 1:12, and a cross slope less than 1:50. Provide handrails at both sides. For ramp construction requirements refer to City of St. Louis Building Division Guidelines and the current edition of ANSI A117.1 as adopted by the City of St. Louis.

reach range: For an object to “be within reach range”, it must be within:

- Minimum height: 15” above the finished floor.
- Maximum height – forward approach: 48” maximum above the finished the floor (44” if reaching over a 24” deep counter)
- Maximum height – parallel approach: 54” maximum off the floor (46” if reaching over a 24” deep counter)

**CHAPTER 2 SCOPING & TECHNICAL REQUIREMENTS
SITE AND BUILDING**

**SECTION 201
GENERAL**

These recommendations provide criteria for making residential sites, buildings and dwelling units comply with universal design principles. These criteria apply to new construction of residential projects in the City of St. Louis funded by the Affordable Housing Commission.

**SECTION 202
SITE**

202.1* Route. Provide at least one accessible route from vehicle drop-off and parking area(s) to entry door complying with 202.2. The accessible route must extend to the public sidewalk (if any).

202.2 Pathway(s). All sidewalks and accessible routes must have maximum 1:20 running slopes and maximum 1:50 cross slopes. Surface to be firm, slip-resistant and smooth. Provide minimum pathway width of 42”.

202.3 Parking. Provide space for at least one accessible parking space serving this site and connected to the accessible route. The accessible space may be on the street. Signs and striping are not required. The intent of this requirement is to make sure that the space can be provided in the future without requiring additional grading, paving, or curbing. If the project is large enough to trigger accessible parking requirements, provide spaces, signage and striping per City of St. Louis Building Code and ANSI A117.1 requirements.

202.3.1 Parking Location. Parking designated for the dwelling should be as close as possible to the house/unit entry and at the same basic level. The intent is to reduce or eliminate any need for residents to negotiate unassisted vertical transitions (ramps etc.) between parking and the entry. Multi-level buildings with elevator service to the parking and entry level(s) are acceptable.

202.3.2 Parking space dimensions (exterior, covered and garage). Provide a 9’ x 19’ minimum area for the vehicle with a minimum 5’ access aisle on one side. Space and aisle to have maximum 2% cross slope in all directions. Surface must be paved, firm, slip-resistant and smooth.

202.3.3 Vertical clearance. Provide 98” minimum vertical clearance at the parking space, access aisle and vehicular approach route.

202.4 Garage. Not required. However, if provided, all portions must comply with the following:

202.4.1 Attached Garage. If the garage is attached to the house, provide a ramp or other means of entering the house through a no-step entry complying with Section 302.2.

202.4.2 Detached Garage. If the garage is detached, provide an accessible route from the garage to a no-step entry to the house.

202.4.3* Garage door (if provided): Provide a child-proof automatic garage door opener and automatic lighting.

SECTION 203 BUILDING

203.1* Entry. Provide at least one no-step entry. This should be a primary house/building entry and must comply with Section 302.1 entry requirements. While it is preferred that the no-step entry be the front entrance to the home, an accessible side or rear entry is permissible when historic or neighborhood requirements preclude access to the front.

203.2 House numbers. Provide address numbers at front and back of house. Comply with Section 302.1. Numbers should be at least 4" tall and contrast with the mounting background by 70% minimum. Numbers should be illuminated or reflective and easily visible at night. See appendix for additional information on contrast.

203.3 Decks. If provided, decks must be accessible from the interior of the dwelling unit. Accessibility may be provided by either step-less transition or ramp. Provide level (no more than 2% slope in any direction) surface with slip-resistant stable finish. No decking gaps greater than 1/4".

203.4 Trash. Provide an accessible route to trash containers or trash drop-off area.

203.5 Mail. Provide an accessible route to the mailbox. Mount mailbox within reach range and provide for either forward or parallel approach.

CHAPTER 3: SCOPING & TECHNICAL REQUIREMENTS SPECIFIC ELEMENTS AND SPACES

SECTION 301 DWELLING UNITS

301.1 Route. The interior accessible route must be continuous through all spaces and must connect to all required elements. Primary living spaces (e.g. living room, family and dining spaces) must be on the accessible route.

301.2 Bathroom(s). At least one bathroom must be on an accessible level and suitable for use as defined in Section 305.1. All additional bathrooms must comply with Section 305.2.

301.3 Bedroom(s)*. At least one bedroom must be on an accessible level and connected to the accessible route.

301.4 Closet shelf supports. Provide adjustable shelf supports extending from floor to ceiling in an accessible bedroom closet. Provide blocking for additional shelving and rod supports in all closets.

301.5 Kitchen. Must be on an accessible level, connected to the accessible route, and comply with Section 304.

301.6* Laundry. Provide space for parallel approach (see Section 103) to both appliances in a side-by-side position on an accessible level. Provide rough-in for combination washer/dryer unit. Set hook-ups to permit future installation of 9" tall platform under the units.

If a parallel approach, the preferred laundry design, is not feasible, the developer may instead purchase and install (at developers' expense) stacking units with controls at or below 54" above the finished floor and service openings within reach range.

301.7 Doors. All exterior door openings must comply with Section 302. All interior door openings must comply with Section 303.

Exception: Doors to shallow closets (24" deep or less) and similar spaces which are not meant to be entered. Utility closets may have door openings narrower than 32" and be deeper than 30" so long as the air handler filter can be easily accessed from outside the space.

301.8 Windows. Provide the following:

303.6.1 Sill height. Locate windows with sills at maximum 32" above the finish floor except over casework.

303.6.2 Operating mechanism. Select windows that are easy to operate. Crank casements requiring less than 5 lbs. of efforts are preferred.

303.6.3 Window locks. Mount locks within reach range (See Section 103).

301.9 Hardware, fixtures and fittings. All door hardware, cabinet hardware, faucets, bath and shower valves, diverters and similar items are to be lever and/or wire handle or D-pull (loop) type. All such items must operate easily using a single closed fist.

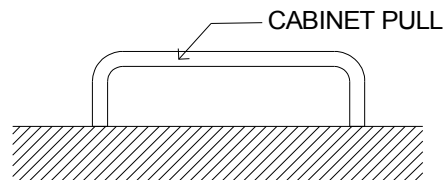

301a Cabinet Pull

Exceptions: Panel box and HVAC filter access panel.

SECTION 302 EXTERIOR DOORS

302.1 Primary Entry. Provide the following:

302.1.1 Door width and type. Minimum 36" wide, standard pivot (hinged) door.

302.1.2* Sidelight. Provide a full length sidelight or other means of seeing visitors from both a standing and seated position.

302.1.3 Threshold. Maximum threshold height is $\frac{1}{2}$ " beveled or $\frac{1}{4}$ " square edged.

302.1.4 Doorbell. Internally illuminated doorbell, wired to allow retrofit of visible interior signal. Mount doorbell at 36" above the level landing outside the door.

302.1.5 Closer. If a closer is installed, comply with current ANSI standards for closing speed and force (see ANSI A117.1 1989, 404.2.8-9).

302.1.6 Weather-stripping. If weather-stripping is installed, the weather seal must allow operation of the door with 5 lbs. of force or less. Seal must not increase the height of the threshold.

302.1.7 Clear floor space. Provide 5' x 5' maneuvering space inside and outside of entry door. At the exterior side of the door, provide a full turning circle (60" radius) of level space clear of the door swing. See illustration 302a.

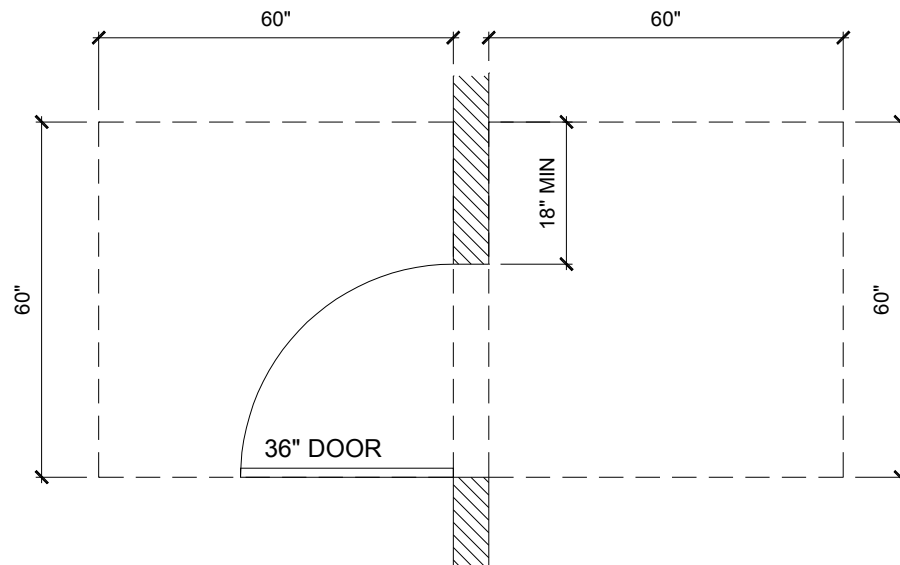

302a Approach areas for primary no-step entry

302.1.8 Covered entryway. Shelter entry from weather with an overhang.

302.1.9* Lighting. Provide outdoor lighting either in porch roof/ceiling or with a sconce mounted on the latch side of the door. Minimum 100 watt capacity fixture.

302.1.10 Optional elements (recommended but not required).

- Provide a package shelf or bench for parcels or groceries near the entry. If the shelf is provided, it must be placed clear of the required approach spaces for the door.
- Provide a covered porch at the entry. The porch roof serves to protect the entry area as well as providing shaded exterior space.
- Provide power stub-in for future installation of an electronic door strike release or power door operator. Most units operate off 24V

302.2 Secondary hinged (pivot) exterior doors. Provide the following:

302.2.1 Door width. Minimum 36" wide.

302.2.2 Clear floor space. Provide 5' x 5' maneuvering space on the pull side(s) of the door and a minimum of a 36" x 48" approach space on the push side.

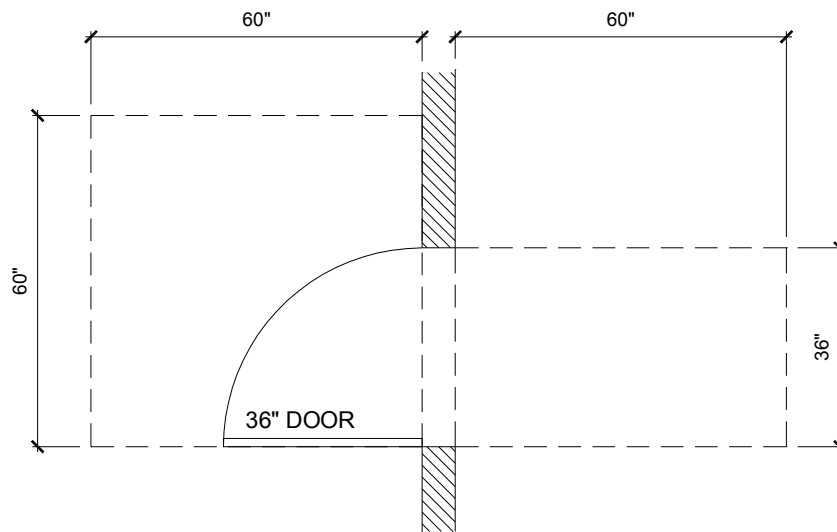

302b Approach spaces for secondary exterior doors

302.3 Exterior sliding doors. Decks may be accessed through sliding glass doors, but these may not serve as the primary entry to the building. The maximum height for the sill/threshold of a sliding glass door is $\frac{3}{4}$ ". Sliding glass doors may require up to 8 lbs. of force to operate. Provide a 42" x 48" approach space to both sides of the sliding door. See illustration 302c.

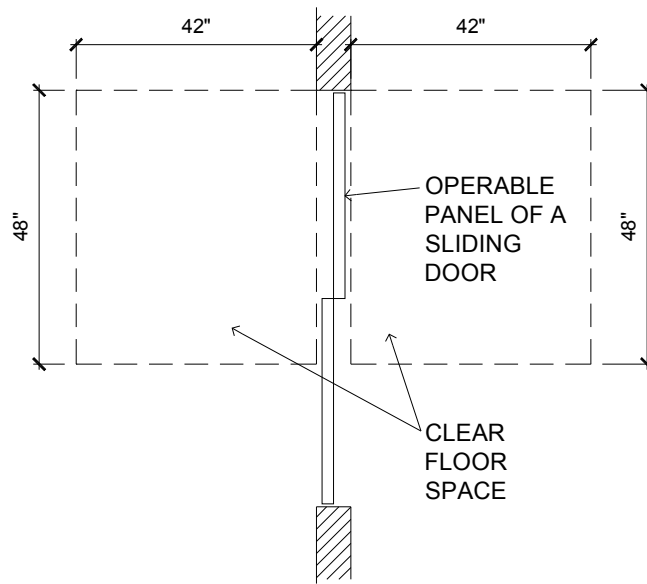

302c
Approach spaces for exterior sliding doors

SECTION 303
INTERIOR CIRCULATION & FINISHES

303.1 Interior Doors and Doorways. Provide the following:

303.1.1* Width. Minimum 32" clear opening.

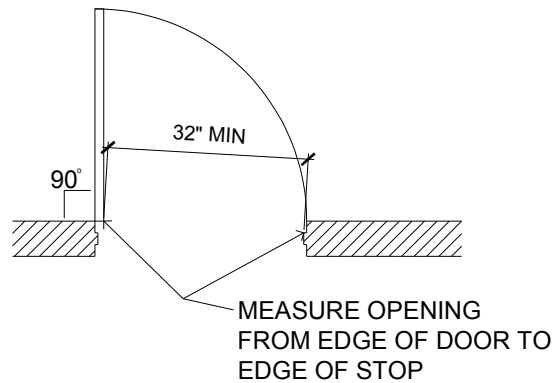

303a Minimum door opening width

303.1.2 Clear floor space. Provide 18" clear approach on pull sides of all doors and a minimum of a 30" x 48" approach space on the push side. On

the push side the approach may be forward (as illustrated) or may be from the side in a 42" minimum width hallway.

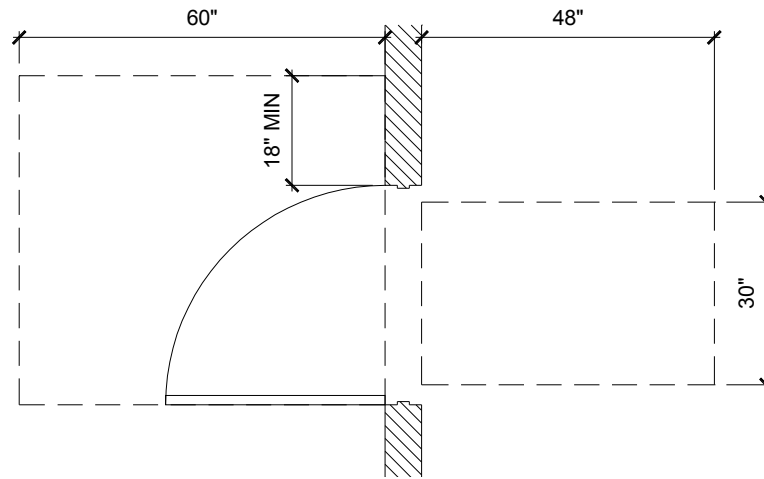

303b Interior door – minimum clear floor spaces

303.1.3 Floor surface changes. Maximum ½" beveled threshold condition.

303.2 Hallways. Provide minimum 42" wide hallways.

303.3 Floor surfaces. Use non-slip and dense surface materials. Do not use pads under carpeting. Use dense pile or loop materials.

303.4* Contrast. High contrast finish selections should include: floor to wall transitions, top treads of stairs, treads & risers, counters and the adjacent flooring and walls.

303.5 Mirror. Provide at least one full length mirror in the bedroom and/or bathroom(s) that connect to the accessible route.

303.6 Interior and exterior stairs (if provided). Comply with the following:

- 303.9.1 Maximum riser height: 7", minimum tread depth 11".
- 303.9.2 Provide handrails on both sides. Extend rails 12" beyond top and bottom risers and parallel to floor. Return rails to wall or newel.
- 303.9.3 Minimum width: 42"
- 303.9.4 Minimum landings: 48" deep.
- 303.9.5 Rough-in power for future lift.

303.7 Space allowances. It is highly recommended that furniture layouts be included with the floor plan. Size rooms generously so that maneuverability is possible with furniture in place.

SECTION 304 KITCHENS

304.1 General kitchen layout. Provide parallel approach space for refrigerator, microwave, sink and stove. If using “U” or parallel/galley type kitchen, provide 60” between front of counter to front of opposite counter. If using an “L” kitchen, provide 42” between the counter and island (if any). Provide continuous counter surface between stove and sink and provide space for microwave and toaster oven on counter surface.

304.2 Sink. Provide the following:

304.2.1 Faucet. Provide single lever faucet with separate sprayer.

304.2.2 Piping. Insulate sink pipes.

304.2.3 Fixture bowl. Provide bowl with 6-7” maximum depth with drain set towards the back of the bowl area. Disposal should be clear of kneespace.

304.2.4 Approach space. Provide front approach knee space for sink. Make cabinet front fold back or provide removable base.

304.2.5 Flooring. Finish floor under sink area.

304.3 Counters. Provide the following:

304.3.1 Material. Avoid mirror finish counters such as gloss laminate. Polished stone is acceptable.

304.3.2 Workspace. Include either a section of adjustable counter surface with kneespace below; or space for a free-standing 24” x 36” table while maintaining required clearances above.

304.4 Appliances. Provide the following:

304.4.1 Range. Provide front controls at range.

304.4.2 Hood. Provide switched exhaust control within reach range of person using the range.

304.4.3 Refrigerator. Include rough-in for icemaker. Provide space for side-by-side appliance or bottom freezer appliance.

304.4.4 Microwave (if provided). Place within reach range.

304.5 Kitchen storage. Provide at least 50% of the storage space within reach range. A pantry unit with pull out shelves and/or an extra closet with shelving for pantry use are recommended methods of addressing this requirement.

304.6 Optional elements (recommended, but not required):

- Full extension drawer glides

- Roll out shelving and/or carts.
- Raised dishwasher
- Side-hinged oven door
- Oven mounted with middle shelf at 34" above finished floor.
- Adjustable shelves in wall and base cabinets.
- Toe kicks at 9" above finished floor.
- Staggered range burners.

304.7 Lighting. Provide fixturing sufficient to provide 55 foot-candle illumination throughout the kitchen workspace. Measure light levels at countertops, appliances and sink.

SECTION 305 BATHROOMS

305.1 Primary bathroom. Provide at least one bathroom on the accessible route with toilet, lavatory, and tub/shower or shower and adjacent storage for personal care items. Do not swing door over any required clear floor space for fixture approach. Room must be large enough to provide turning space for a person using a wheelchair. Refer to ANSI A117.1 for additional information on minimum dimensions for turning. Include the following features:

305.1.1 Phone. Provide phone jack.

305.1.2* Toilet. Locate the toilet: 18" off a sidewall – in a clear space minimum 48" wide, 60" deep. Install a fixture with the flush valve on the open side of the toilet.

305.1.3 Seat. Provide toilet with seat height of 17".

Exception: unit design for specific occupant requesting higher or lower fixture.

305.1.4* Tub (if provided). Provide a clear 30x48 approach space aligned with side of tub. See illustration 305a.

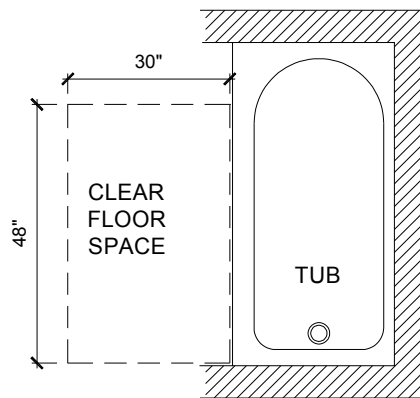

305a Clear floor space for tub approach

305.1.5 Controls. Locate tub/shower controls the side of the fixture centerline. See illustration 305b.

305.1.6 Blocking. Provide blocking for grab bars in a variety of positions. See illustration 305b.

305.1.7 Shower. Provide personal shower unit on 30" minimum slide bar. Include shower head with cut off thumb control at head. Provide minimum 60" long hose.

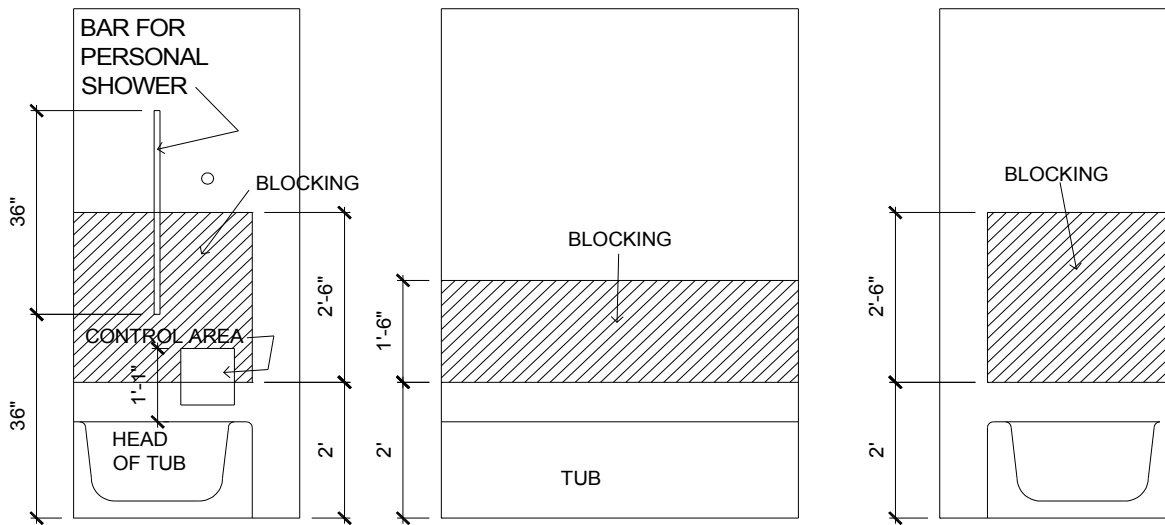

305b Tub blocking and controls

305.1.8* Shower stall (if provided). Minimum shower size is 36" square (interior clear dimensions) with blocking in the walls for grabs and seats. Provide maximum 1/2" high curb installation at 36" square units.

305.1.9 Lavatory. Provide 30x48 approach space for both parallel and forward approach. Provide finished floor under the lavatory and provide one of the following: removable cabinet, fold back vanity doors or wall hung fixture/counter with kneespace.

305.1.10 Mirror. Size the mirror over the lavatory as follows. Place the bottom edge just above the backsplash (38" above the finished floor maximum). The top edge must be at least 66" above the finish floor.

305.1.11 Lighting. Provide extra lighting at sides or above lavatory and in or adjacent to the tub/shower area. Maintain minimum 55 foot-candle light levels in the bathroom.

305.1.12 Power. Provide at least one (1) GFCI electrical outlet located within reach range (see Section 103).

305.2 Secondary bathroom(s). Provide a 30"x48" clear floor space beyond the reach of the door swing. Include the following features:

305.2.1 Toilet. Locate the toilet: 18" off a sidewall – in a clear space minimum 48" wide, 60" deep. Install a fixture with the flush valve on the open side of the toilet.

305.2.2 Seat. Provide toilet with seat height of 15" (17" optional).

305.2.3 Tub (if provided): Provide 30" x 48" approach space aligned with side of tub. See illustration 305a.

305.2.4 Controls. Locate tub/shower controls the side of the fixture centerline. See illustration 305b.

305.2.5 Blocking. Provide blocking for grab bars in a variety of positions at toilet, tub and shower areas.

305.2.6 Shower (if provided): Minimum 34" square with blocking in the walls for grabs and seats. Provide 30" x 48" clear floor space adjacent to the open side of the shower.

305.2.7 Lavatory. Provide 30" x 48" clear floor space for either parallel or forward approach centered on the bowl.

SECTION 306 LIFE SAFETY, ENVIRONMENTAL & ELECTRICAL ELEMENTS

306.1 Smoke alarms. Wire to allow for future installation of visual alarms.

306.2 Thermostats. Mount the thermostat at 48" above the floor in a position that allows either forward or parallel approach. Unit should have large, legible control markings and be user friendly.

306.3 Electric panel. Provide parallel approach space for electric panel. Mount with top operating switch/shut-off at 54" above the floor and bottom of panel no less than 18" above finished floor. Electric panel is to be located on an accessible level connected to an accessible route.

306.4 Outlets, phone jacks and data ports. Mount outlets, phone jacks and data ports at 18" above the finish floor minimum.

306.5 Switches. Mount switches at 36-42" above finish floor. Use luminous rocker or toggle switches.

SECTION 401 EXCEPTIONS AND WAIVERS

401.1 Exceptions and waivers. Under limited circumstances, the Affordable Housing Commission may grant exceptions to UD Requirements, but only

when the Commission determines compliance is architecturally infeasible. In such cases, the Commission expects the developer to offer alternative designs, at the developer's expense, that emphasize accessibility on as integrated a basis in the total design, as possible.

Any misrepresentations may result in a withdrawal of Trust Fund financing. The developer must notify the Trust Fund immediately if it becomes aware of design changes or information which would change any statement or representation previously submitted to the Trust Fund. The developer understands and accepts responsibility for all information and representations submitted and the Commission retains its right to seek legal redress and repayment of funds advanced for the project if UD Requirements have not been fully met.

No exceptions will be granted to the basic four elements: 1) one no-step entry; (2) minimum door and hallway width requirements; 3) provisions for usable bathroom facilities in the unit; and 4) at least one accessible bedroom on an accessible level connected to an accessible route.

401.2 Consulting. Exceptions and waivers will not be routinely granted. Applicants for Affordable Housing Trust Funds are encouraged to consult with a qualified architect early in the application process.

Appendix A Design Notes and Explanatory Comments

103A Defined Terms. Additional helpful definitions of common terms (e.g. cross slope and running slope) can be found in the current edition of ANSI A117.1, "Accessible and Usable Buildings and Facilities".

103A Ramps. Ramps that rise less than 6" total height do not require handrails or edge protection.

201.1A Concealed routes. Sloping walks, earth berms, retaining walls, bridges or porches may be used instead of ramps to provide the accessible route.

202.4.3A Garage lights. Automatic lighting in the garage can be controlled with a switch at the pedestrian entry and triggered by the garage door operator, or can be connected to a motion sensor. Provide adjustable delay for shut-off if light is automatic.

203.1A Entry. "No-step" and "step-less" entries are to comply with the requirements of these standards. An "accessible" entry must comply with current ANSI A117.1 standards as adopted by the City of St. Louis.

301.3A Bedrooms. Compliance with the first floor bedroom requirement can be achieved if a room on the accessible level (e.g. a family room) is designed to be convertible to a bedroom without modification of door openings. Convertible

bedrooms must be designed so that a standard door and frame meeting Section 303.1 requirements can be added to an existing framed opening without size modifications. A closet is required.

301.6A Washer/dryer units. Stacked washer dryer units may be installed so long as the required space for side-by-side units is provided. If side-by-side units are not accessible via a parallel approach, the project must still provide the required space to accommodate side-by-side units. In such instances, the developer may choose to design the space, purchase, and install stacking units with controls at or below 54" above the finished floor and service openings within reach range.

302.1.2A Sidelights. In areas where a full length sidelight presents a potential security threat – provide other means of seeing the front door approach space from inside. This can take the form of extra wide angle peepholes, high/low peepholes (36" and 60"), side windows at more remote locations, or cameras.

302.1.9A Lighting security. Exterior lighting run by motion sensor can provide both energy savings and added security and is recommended but not required.

303.1.1A Door size. For hinged doors, a 34" wide door leaf is required to provide a 32" wide opening. A wide throw hinge can provide extra opening width where space is limited.

303.4A Contrast. Effective visual contrast is dependent on light reflectance values and saturation values of light and dark surfaces. Color differences alone can not achieve contrast. Signs and surfaces changes are most easily seen by persons with low vision when characters or edges contrast with their background by at least 70 percent. For additional discussion, see ADAAG A4.30.5.

305.1.2A Toilets. Toilets are preferably located in a larger than 36" wide space. Note: Blocking for grab bars at side and back of toilet is required in all bathrooms and toilet rooms – increasing the area covered by blocking is recommended. A minimum 2x10 mounted with the bottom edge 30" above the finished floor running continuously along the side and rear of the toilet space is recommended.

305.1.4A Tubs. Non-slip bottom surfaces are preferred at bathtubs. However, non-slip strips or suction cup mats can be applied in the future.

305.1.8A Shower. A 60" x 36" roll-in unit, with no lip or threshold is recommended, but not required. If this type of shower is installed, provide a floor drain in the shower and another in the floor space just outside the shower. Additional information concerning detailing these units is available at several of the resources listed in the Appendix.

Note: A part of UD that is rarely discussed or addressed is the need for housing that is easily maintained and is efficient in its use of energy. It is pertinent and part of universal design to balance appropriately increased initial costs for items such as added insulation and higher efficiency appliances and water heaters and the long term life costs that will be passed along to future residents and Owners.

Appendix B Universal Design in Rehab and Restoration Projects

The Affordable Housing Commission does not require the application of Universal Design Criteria to rehabilitation and conversion projects. However, the incorporation of UD elements into such projects is highly recommended wherever possible and the inclusion of such elements may be a factor in the funding evaluation process.

In multifamily conversion and loft projects, the interior elements can usually be incorporated into the design throughout the project. Historic requirements and existing conditions can add some difficulty to the viability of making windows easily operable and all entries step-less.

Appendix C References and Resources

Americans with Disabilities Act Architectural Guidelines (ADAAG), 28CFR Part 36, Revised as of July 1, 1994. Reprinted by the Department of Justice.

Curbless Showers, An Installation Guide, Center for Universal Design, North Carolina State University http://www.design.ncsu.edu/cud/pdf_files/Curbless.pdf
Note: the NCSU website has many useful references on UD.

Technical Bulletins, Guidelines and Studies posted at the website provided by the Access Board: www.access-board.gov

General Resources and information: <http://www.udeducation.org/>
Residential Checklist and Sample Plans: <http://www.ksu.edu/humec/atid/UDF/>

Covington, George and Hannah, Bruce *Access By Design*. New York, Van Nostrand Reinhold 1997.

Preiser, Wolfgang and Ostroff, Elaine editors. *Universal Design Handbook*, New York, McGraw Hill 2003.

Goldsmith, Selwyn *Universal Design, A Manual of Practical Guidance for Architects*. Oxford, Architectural Press. 2000

Leibrock, Cynthia *Beautiful Barrier Free, A Visual Guide to Accessibility*. New York, Van Nostrand Reinhold 1993.

Steven Winter Associates, *Accessible Housing By Design, Universal Design Principles in Practice*. New York, McGraw-Hill 1997.

Wylde, Margaret, Adrian Baron-Robbins and Sam Clark, *Building for a Lifetime, The Design and Construction of Fully Accessible Homes*. Newtown, CT, Taunton Books and Videos 1994.